

## EZREACH<sup>™</sup>

**MODEL BFEZ168 SERIES (AquaGo 1003)**  
COMPACT, WALL MOUNTED, SENSOR OPERATED,  
REFRIGERATED BOTTLE FILLER

### STANDARD FEATURES

- n *Rough-Ins Match Other Manufacturer's Water Coolers for Easy Replacement*
- n *Hands-Free Sensor Operation*
- n *Optional -WF1 & -WF3 Filter Cap Has Auto-Shut Off for Easy Changing of Filter Without Turning Off Supply*
- n *Access Panel for Ease of Maintenance*
- n *Lead Free*
- n *Housing is Satin Finish Stainless Steel Or Gray Powder Coat Finish*
- n *120VAC/9.0VDC Plug-In Transformer For Bottle Filler*
- n *Laminar Flow Water Supply*
- n *Sensor Has a 20 Seconds Maximum Run Time*
- n *1 GPM Fill Rate*
- n *100-Mesh Inlet Strainer*

### SUGGESTED SPECIFICATIONS

#### Electric Refrigerated Bottle Filler

EZREACH Model BFEZ168 is a self-contained, Chilled Bottle Filler that delivers a minimum of **8.0 GPH** (30.3 LPH) of water at 50°F (10°C) cooled from 80°F (26.7°C) inlet water and 90°F (32.2°C) ambient. Unit shall be activated by a front mounted 9 Volt Infrared Sensor. Basin shall be constructed from 304 Stainless Steel polished to a #4 satin finish and have an Integral Drain. Cabinet shall be either Galvanized or Galvannealed Steel with Gray Powder Coat Finish or Stainless Steel with Satin Finish. Cooling system shall use R-134a Refrigerant and be Capillary Tube regulated. An Adjustable Thermostat with an off position shall regulate the refrigeration system. Unit shall be listed by Underwriters Laboratories for both the US and Canada and is compliant to the Air Conditioning and Refrigeration Institute Standard 1010. Unit is certified to ANSI A117.1, Public Law 111-380 (NO-LEAD), CHSC 116875 and NSF/ANSI 61, Section 9. When installed properly, the Bottle Filler complies with ADA forward and side reach height requirements ADA Standing Person, and ADA Child. Unit shall still deliver ambient water temperature to the Spout in the absence of electrical power as long as -BAT option is used and there is a pressurized water supply. Bottle Filling unit shall include Sensor Operated activation with a 20 second maximum run time. LED Lights illuminate the Bottle Fill area and brighten when a bottle is detected, with optional -BCD (Bottle Counter Display) only. Optional -BCD (Bottle Counter Display) indicates the quantity of 16 oz disposable Plastic Bottles saved from a land fill and also displays the Water Filter status.

Bottle Filler housing construction will be 20 gauge Stainless Steel with a satin finish and will also include components manufactured from Antimicrobial, impact resistant ABS. Bottle Filler shall provide approximately 1 GPM (3.8 LPM) flow rate with a Laminar Flow Spout to minimize splashing.

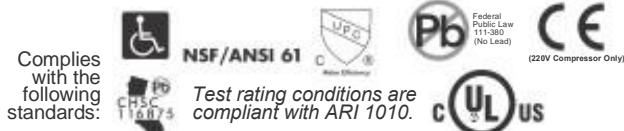

H<sub>2</sub>O  
to go!



PATENT# Pending  
PATENT# D873,606



**"RATED FOR INDOOR USE ONLY"**

Model Number	GPH*	Rated Watts	Full Load Amps	Approx. Shipping Weight
BFEZ168 AquaGo 1003	8.0	335	4.4	100 lbs.

\* GPH of 50°F water at 90°F ambient room temperature and 80°F inlet water temperature  
Compressor motor operates on 115 Volt / 60 Hz single phase.

### MODEL:

(Must Specify Water Cooler)

AquaGo 1003

BFEZS168 Compact Bottle Filler, Stainless Steel Housing with Satin Finish Bottle Filler

### BOTTLE FILLER

BCD Bottle Filler with Sensor Operation with Bottle Counter Display

### OPTIONS Included

(additional costs may apply)

WF 3000-Gallon Capacity, NSF 42+53, 1-Micron Lead Reduction Filter  
220V 220-240 volt / 50 Hz Compressor



WARNING: Cancer and Reproductive Harm - www.P65Warnings.ca.gov

## EZREACH™

### MODEL BFEZ168 SERIES

COMPACT, WALL MOUNTED, SENSOR OPERATED,  
REFRIGERATED BOTTLE FILLER

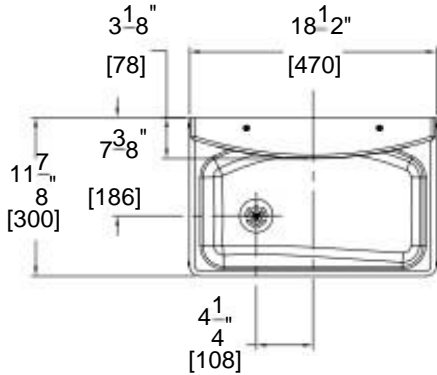

**GENERAL NOTES:**

1. ALL DIMENSIONS ARE IN INCHES [mm]
2. \*DIMENSIONS SHOWN ARE FOR RECOMMENDED ADULT HEIGHT. ADJUST VERTICAL DIMENSIONS AS NECESSARY TO COMPLY WITH FEDERAL, STATE & LOCAL CODES.
3. P-TRAP AND INLET STOP NOT PROVIDED.
4. ALLOW 4 INCHES [102 MM] MINIMUM CLEARANCE PER SIDE FOR VENTILATION

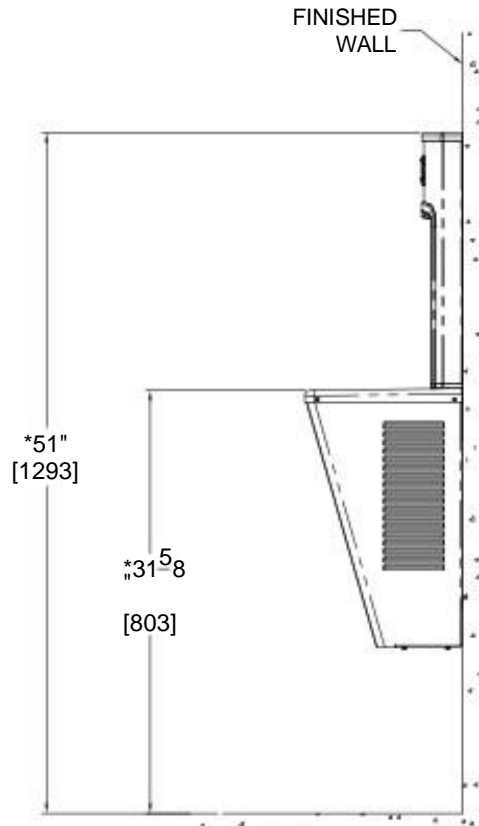
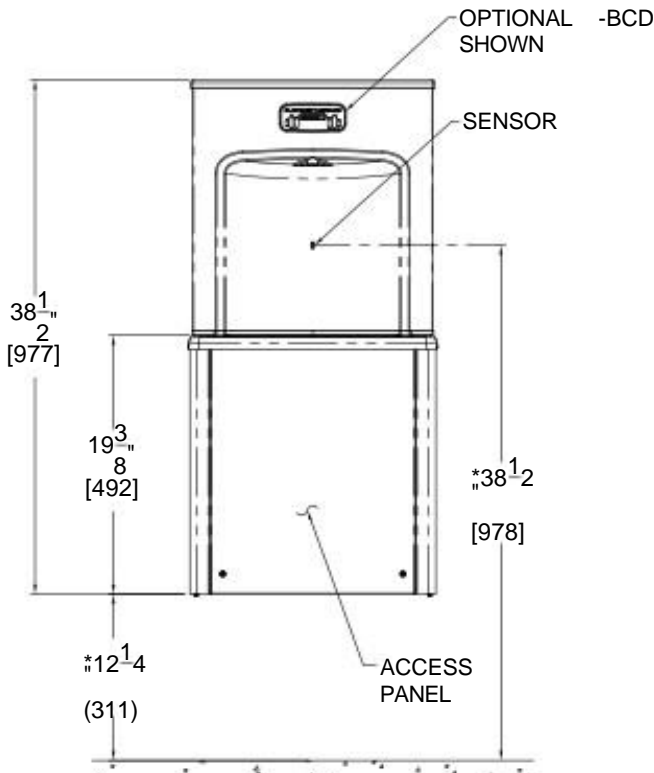

Murdock Mfg.™ warrants that its products are free from defects in material or workmanship under normal use and service for a period of 18 months from date of shipment. The sealed refrigeration system is warranted for five years. Murdock's liability under this warranty shall be discharged solely by replacement or repair of defective material, provided Murdock™ is notified in writing within one year from date of shipment, F.O.B. Industry, California.

Model Number & Options _____	Quantity _____	All dimensions are subject to manufactures tolerance of plus or minus 1/2" nominal and subject to change without notice. Murdock assumes no responsibility for use of void or superseded data. Dimensions may change with the addition of optional accessories. Murdock Mfg.™, Member of Morris Group International™. Please visit <a href="http://www.murdockmfg.com">www.murdockmfg.com</a> for most current specifications.
Company _____		
Contact _____ Title _____		
Signature (Approval for Manufacturing) _____	Date _____	
_____		